

**SPECIFICATION FOR THE MANUFACTURE AND DECORATION OF SCREW CAP CLOSURES**

Prepared by Ozpak Pty Ltd	Date of Issue
Based on Guidelines prepared by W.P.A. members: Barossa Bottling Services, Best Bottlers, Hunter Bottling Co., McLaren Vale Bottlers, Ozpak, Portavin, Prowine, Torresan Estate & Vinpac	5 th September 2014

THESE SPECIFICATIONS ARE FOR CIRCULATION TO CUSTOMERS, MANUFACTURERS AND SUPPLIERS OF SCREW CAP CLOSURES. PLEASE MAKE SURE THE APPROPRIATE PEOPLE IN YOUR COMPANY ARE GIVEN A COPY OF THIS DOCUMENT.

These Specifications will be updated regularly.

PURPOSE

1. To inform customers, manufacturers and suppliers of Ozpak's Specifications for screw cap closures (including but not limited to Guala, Interpack & Orora) to ensure that these are capable of being applied mechanically on Ozpak's bottling lines.

GUIDANCE

2. All queries regarding the requirements of these Specifications should be directed through the Ozpak's Customer Service Manager.

RESPONSIBILITY

3. Customers should ensure screw cap closures provided to Ozpak are manufactured with reference to the information contained in these Specifications.
4. The screw cap closure should be manufactured to the specification of the particular bottle finish dimensions they are intended to fit. Information on bottle finishes can be sourced through Ozpak's Customer Service Manager.
5. Customer supplied closures should be approved by Ozpak prior to bottling to confirm we can achieve a mechanical application on our bottling lines.

REQUIREMENTS

6. Technical drawings and application specifications should be supplied in PDF format to Ozpak's Customer Service Manager at least 6 weeks before the scheduled bottling date.

7. Screw cap closures must comply with current existing regulations and legislation (that is European and FDA – Food and Drug Administration) for products in contact with food. Customers are required to give a copy of this declaration to your Customer Service Representative.
8. All closures must conform to the Winemakers Federation of Australia Wine Packaging Guidelines unless otherwise specified in this document. Acceptable tolerance levels and requirements for decoration of screw cap closures are contained in the following tables:

TABLE 1

Supplier	Size	Diameter (ØM)	1 st Inside Diameter (Ød)	2 nd Inside Diameter (Ød2)	h2	h
Guala/Orora	22 X 30	22.7	21.65	22.10	12.6	29.8
Orora	25 X 42	25.6	24.7	25.10	12.5	42.8
Guala	25 X 42	25.75	24.8	25.27	13.23	42.0
Guala	28 X 15	28.5	28.0	28.0	11.8	15.1
Guala/Orora	28 X 44	28.4	27.5	27.85	16.0	43.9
Guala	30 X 44	29.9	28.9	29.34	18.0	43.9
Orora	30 X 50	29.7	28.7	29.15	18.0	49.9
Guala	30 X 50	28.9	28.9	29.34	18.0	49.9
Guala/Orora	30 X 55	29.7	28.7	29.15	18.0	54.9
Orora	30 X 60	29.7	28.7	29.15	18.0	59.9
Guala	30 X 60	29.9	28.7	29.25	18.0	59.45
Interpack	30 X 60	29.9	28.65	29.34	18.0	60
Orora	31.5 X 60	31.4	30.5	30.95	18.0	59.9
Guala	31.5 X 60	31.65	30.54	31.05	18.2	60.0

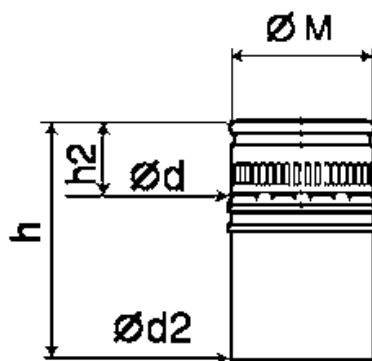

TABLE 2

Critical issue	Description	Tolerances
Dimension	Length	As specified in Table 1 (+/- 0.3)
	Diameter (ØM)	As specified in Table 1 (+/- 0.3)
	1 st (Ød) and 2 nd (Ød2) inside Diameter	Minimum as specified in Table 1
	Ovality	Tolerance (+/- 0.4).
Material & Thickness	Aluminium alloy 8011 H24 or H14	H24 = Thickness 0.23mm +/- 0.01 (Guala & Orora) H24 = Thickness 0.23mm +/-0.02(Interpack) H14 = Thickness 0.225mm +/- 0.015
Liner	Liner condition	No holes, scratches, doubles, missing or incomplete liners
	Liner material	Material which is in contact with the wine must conform/ comply to the Australian, EU & FDA regulations for food contact materials
Paint	Internal	Epoxy-phenolic lacquer, suitable for contact with alcoholic liquids and must conform/ comply to the Australian, EU & FDA regulations for food contact materials
	External	Polyester or vinyl base coating - Polyester inks.
Print	Artwork	Shall not differ from supplied artwork.
	Print	Clear, no smudging & shall not rub off/scuff.
	Registration	≤ 1.0mm off centre
Colour	Darker/lighter	+/- 5% or darker/lighter &/or ≤ 3 Delta E
Appearance		Not damaged/crushed

Critical issue	Description	Recommendation/Observation
Packaging	Outer packaging type	High density Polyethylene bags then into a cardboard shipper, suitable for contact with dry foodstuffs & taped closed.
Application	Vertical load, roller pressures	Supplier application specification must be supplied.
Pressure retention	Bubble point test	Supplier must state if product is suitable for sparkling product and must provide test parameters

PACKING AND DELIVERY

9. Screw cap closures should be packed in a suitable carton to avoid crush damage. Detailed information on the packing and delivery of dry goods is contained in Ozpak's Specifications for the Documentation, Packaging and Delivery of Customer Supplied Dry Goods attached to this document.

AUSTRALIAN PACKAGING COVENANT

10. As part of Australia's sustainability objectives, we request that where practical dry goods are made using recyclable materials and are packed using recyclable materials.

INSPECTION AND TESTING

11. The manufacturer/supplier must maintain a plan of inspection and testing of the product at all stages of production for critical control defects. Parameters must be set up to ensure checks are carried out with sampling and inspection at the critical control points.

REFERENCES

Winemakers Federation of Australia – Wine Packaging Guidelines November 2010 www.wfa.com.au
 Australian Packaging Covenant www.packagingcovenant.org.au



Ozpak Pty Ltd
 ABN 57 091 370 446
 201 Odwyer Road
 Nagambie VIC 3608
 P.O. Box 133
 Nagambie VIC 3608
 Telephone + 61 (0) 3 5736 2800
administration@ozpak.com.au

